

# Semi-Automatic Labeling

*Exceed quota on your table top.*



R310



R310 Front & Back

## R310

### Round Product Labeling System

- Roll-on labeling from ampules to gallons
- Quick and easy changeover
- Photoelectric label sensing
- Foot switch activation

### Front & Back

- Single or front & back labeling
- Label widths up to 9 inches
- Photoelectric label sensing
- Foot switch activation

## L60

### Tamp Apply Labeling System

- "Made-to-order" table top labeling
- "Quick change" tamp heads
- Photoelectric label sensing
- Product fixtures "Made-to-order"
- Foot-switch or micro-switch activation



**UNIVERSAL**  
labeling systems

Engineering  
labeling solutions.

# SPECIFICATIONS

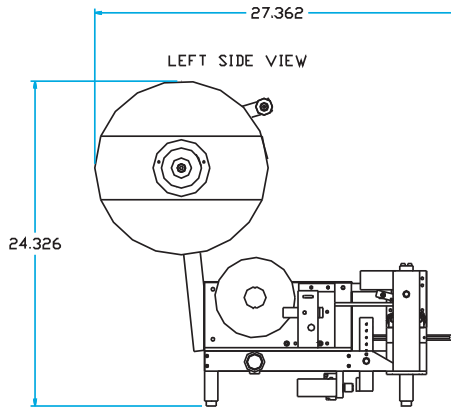
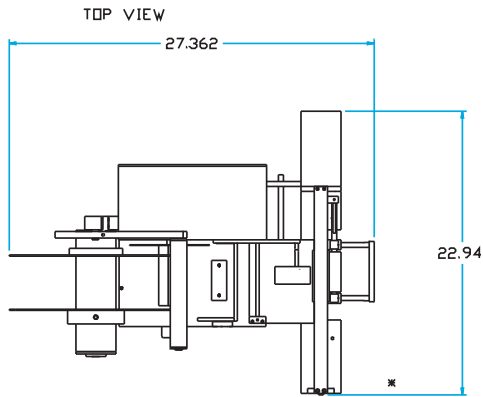

## R310

- Product sizes: .5" to 6" diameters
- Web width: up to 6.75"
- Label roll capacity: up to 12" Ø
- Air: 20 PSI minimum.
- Electric: 120VAC = +/-10%

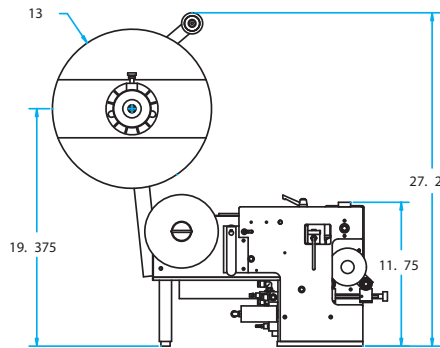
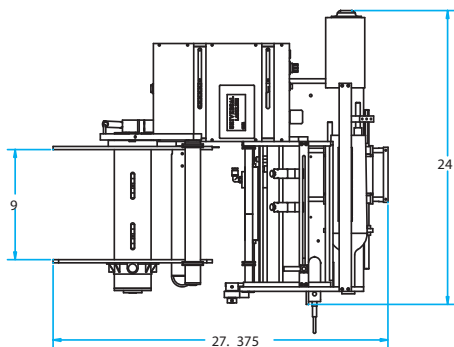

## R310 Front & Back

- Product sizes: .5" to 6" diameters
- Web width: up to 9"
- Label roll capacity: up to 12" Ø
- Air: 20PSI minimum.
- Electric: 120Vac= +/- 10%.

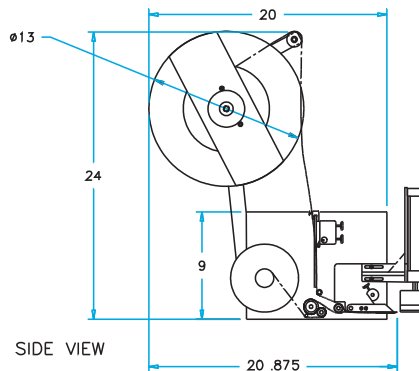
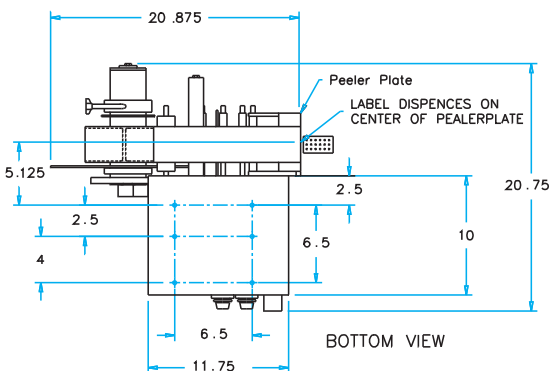

## L60

- Web width: up to 6.5"
- Label roll capacity: up to 12"Ø.
- Electric: 120 VAC = +/-10%.
- Air: 40 PSI Tamp.

Distributed by:  
 MPI Label Systems  
 866-364-3585  
[www.mpilabels.com](http://www.mpilabels.com)  
[info@mpilabels.com](mailto:info@mpilabels.com)