

Small Diameter Automatic Round Product Labeling

R315

Features:

- Complete tabletop system
- Variable speed components.
- State-of-the-art control package
- Quick change product carrier
- Choose your Universal applicator
- Overhead label wrapping station.



Made-to-order product carriers, accommodating virtually any small diameter product.



Choose your Universal applicator, including Print & Apply.



Optional hot stamp imprinter for variable information like expiration dates and lot codes.

UNIVERSAL
labeling systems

Engineering
labeling solutions.

SPECIFICATIONS

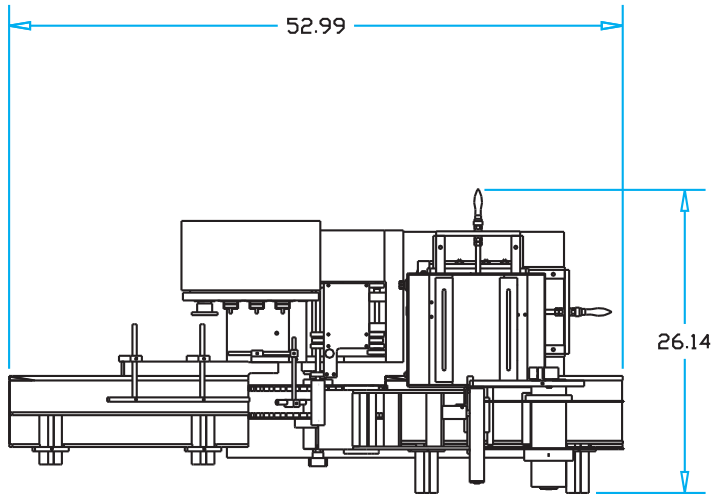

R315

- 26" w x 53" L x 41"H
- Speed: up to 1200 inches per minute.
- 6.5" wide web capacity.
- 12" label roll capacity 3" core.
- Electric: 120 VAC +/-10%
- Unit weight: approximately 165 lbs. (Shipping weight approximately 500 lbs.)

Options

- Additional product carriers
- Framework base with casters and leveling pads
- SL1500 label applicator or UR II Printer Applicator
- Automatic speed following
- Vibrating in-feed chute assembly with motor
- Hot stamp imprinter

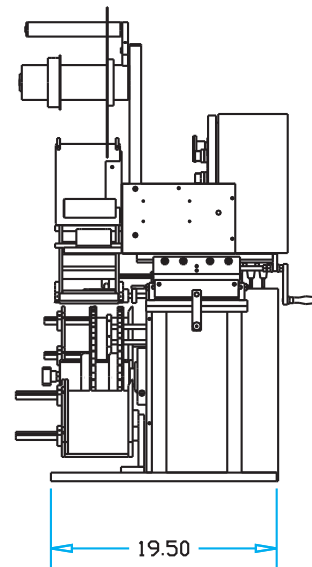
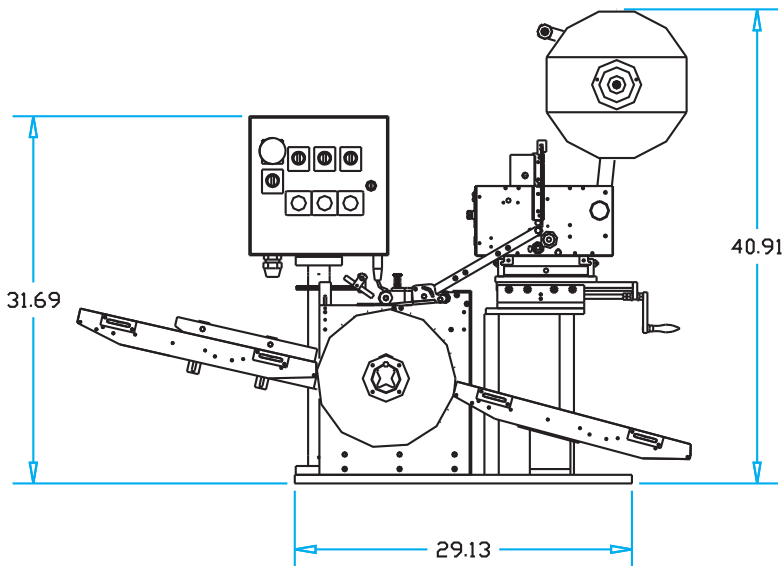

Distributed by:
MPI Label Systems
866-364-3585
www.mpilabels.com
info@mpilabels.com