

MPI 200

Compact Automatic Shrink Band APPLICATOR

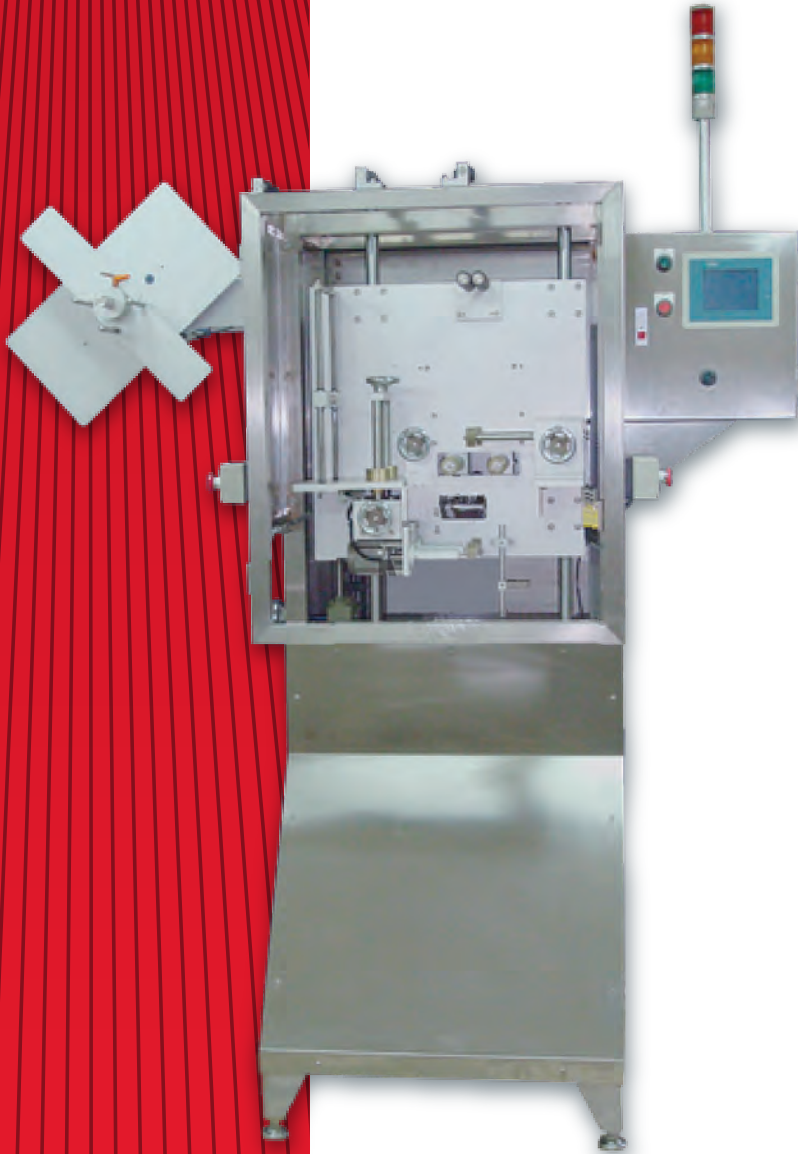

DISPLAY & FORM:

- Compact and smooth layout, provides strong presentation with minimal space occupation and external cleaning.
- Constructed in SU304 Stainless Steel to ensure structural strength and superior performance.
- Simple mechanical design to reduce operating complications and provide easy maintenance.
- User-friendly touch screen HMI interface features error message and feedback information.

DESIGN & FUNCTION:

- Simple and fast change-over reduces production down-time for different container sizes.
- Internal memory stores up to 10 sets of parameters - a great time saver for operators during production.
- Rotary cutting blades provide maximum speed and high accuracy in trimming shrink materials.
- Warning sensors and lights for material shortage or machine errors allowing maximum efficiency.
- Protect operator's safety with physical guarding and high electrical standards.
- Various options and accessories can be chosen to customize operations and achieve flawless production.

MODEL MPI-200

Application Rate	Up to 200 Products Per Minute
Electrical	3 Phase - 230/240 Volt; 440/480 Volt
Bottle Diameter	.984" (25mm) - 2.559" (65mm)
Lay Flat	2.047" (52mm) - 4.015 (102mm)
Label Length	1.771" (45mm) - 6.299" (160mm)
Label Thickness	.001" (.035mm) - .003" (.08mm)
Label Material	PET-G, PET, PVC, OPS
Machine Dimensions	29.527" (750mm)L x 31.496" (800mm)W x 78.74" (2000mm)H



Equipment Division

1421 West Main Street, Alliance, OH 44601

Ph: 330-238-4200 Toll Free: 866-364-3585

Fax: 330-823-5483

Mfg. Plants in CA, CT, IL, NC, OH, TN, TX

www.mpilabels.com info@mpilabels.com

MPI 200

Compact Automatic Shrink Band APPLICATOR

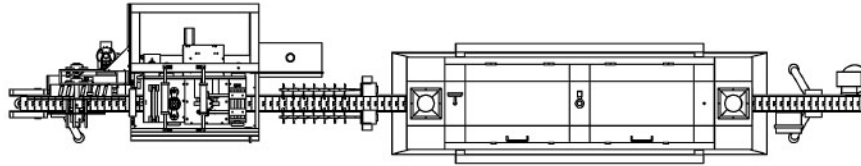

LEGEND

1. IN-FEED SCROLL
2. MAIN APPLICATOR
3. POSITION BRUSH
4. STEAM TUNNEL (Heat tunnels available)
5. CONVEYOR BELT
6. INVERTER FOR CONVEYOR SPEED CONTROL

Please Note:
This schematic drawing is for illustration purpose only, actual system may vary due to the customization.

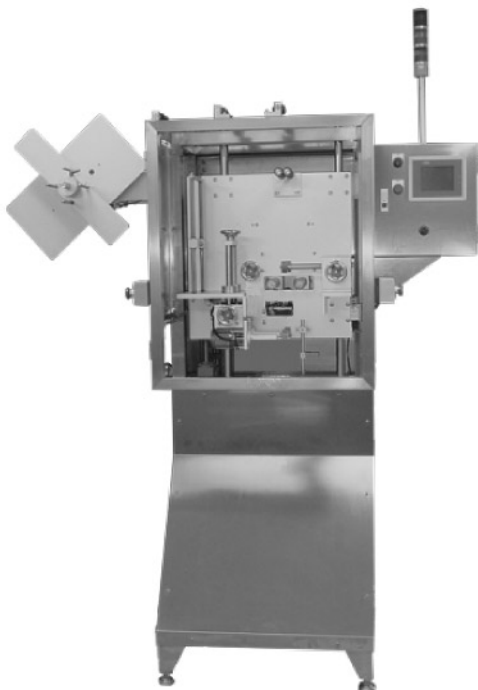
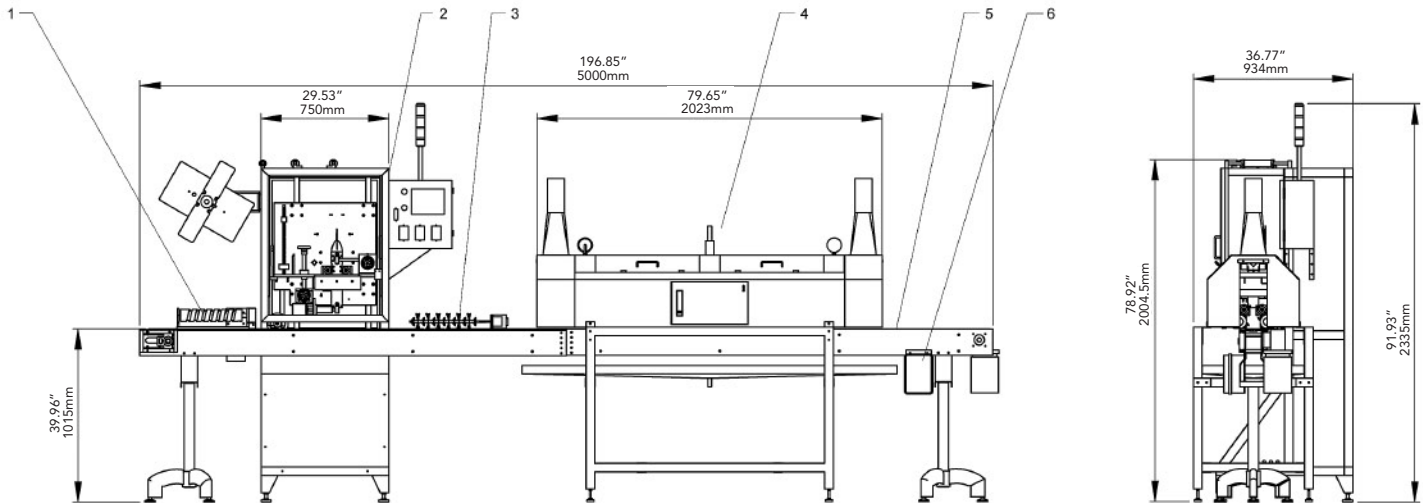

Equipment Division

1421 West Main Street, Alliance, OH 44601

Ph: 330-238-4200 Toll Free: 866-364-3585

Fax: 330-823-5483

www.mpilabels.com info@mpilabels.com

Mfg. Plants in CA, CT, IL, NC, OH, TN, TX

1169688 3/09