

OEM Solutions

The “Standard” for all automatic print & apply Labeling



M8490Se - High Resolution OEM Printer

The industrial OEM high-speed printers are ideal for a range of applications, including:

-  **Compliance Labeling**
-  **Warehouse Logistics**
-  **Pallet Tracking**
-  **Retail Labeling**
-  **Product Authentication**
-  **Cross-Docking**
-  **Shipping Labels**

Throughput

The M8490Se continues to set the benchmark for high-resolution OEM printer performance in automatic label applicator systems. Utilizing the latest in 32-bit microprocessor technology, along with 16 MB of standard RAM, the M8490Se provides virtually instantaneous “time to first label out”. When printing at its maximum print speed of 8 ips, the M8490Se is capable of handling your most demanding automatic print apply application.

Interchangeable

The height, width and location of mounting holes are identical to earlier SATO OEM print engines, making it easy to upgrade to the M8490Se. Plus, the M8490Se is compatible with the programming commands of the M8490S, making it a simple drop-in replacement.

Host Interface Flexibility

Designed with a modular interface slot, the M8490Se allows for a wide variety of interface options to be easily installed and field upgraded. These bi-directional interfaces include a high-speed IEEE1284 Parallel (ECP), RS232C Serial, USB, 10BaseT/100BaseTX Ethernet and 802.11g Wireless Ethernet.

Legendary Reliability

Your labeling application is demanding and uptime is paramount. The M8490Se was designed to provide reliable performance over extended periods of time. It was specifically developed as a high-duty cycle applicator print engine... it is not a repackaged desktop printer. Even the heavy gauge steel enclosure was designed for production environments. Yet, internal access for maintenance is simple.

SPECIFICATIONS



PRINTER MODEL		M8490Se
PRINT SPECIFICATIONS		
Print Method	Direct Thermal/Thermal Transfer	
Print Resolution	305 dpi (12 dpmm)	
Max. Print Speed	8"/s (250mm/s)	
Max. Print Area	4.4" (112mm) W x 32.8" (833mm) L	
MEDIA SPECIFICATIONS		
Sensor Type	Transmissive sensor for die cut labels & tags. Reflective sensor for use with preprinted sensing marks. Automatic, programmable setting of top form.	
Media Type	Die cut labels, plain paper facestock and synthetics. Maximum unwind torque: 8 ft./lbs.	
Back Feed	Adjustable, ± 10" (255mm)	
Media Size	Width	Max. 5.27" (134mm) Min. 1" (25mm)
		Min. 4" (102mm) with RFID Tag
	Length	Min. 0.24" (6mm) Min. 4" (102mm) with RFID Tag <i>Note: Minimum label length at print speeds greater than 6 ips is 1" (25.4 mm)</i>
Thickness	0.002" – 0.0106" (0.06 mm – 0.268 mm)	
Ribbon	Max. 5.25" (133mm) W x 1968' (600m) L Min. 1.6" (39.5mm) W, Face-In Wind	
FONT / SYMBOLOGIES		
Font	Bitmap - 12 proportional, mono-spaced and outline fonts (Code table 858). Internal CG Triumvirate & CG Times fonts scalable from 2 to 99 points. Optional downloaded TrueType fonts.	
Barcode Symbologies	Linear	UPC-A/E, EAN-8, EAN-13, Code 39, Code 93, Code 128, Codabar, MSI, Bookland, Industrial 2/5, Interleaved 2/5, Matrix 2/5, Postnet™, GS1-128, GS1-DataBar™, Intelligent Mail® Barcode (IMB)
	2-D	PDF417, Micro PDF417, Truncated PDF417, Maxicode™, Data Matrix, QR Code, Composite Symbology
COMMUNICATION INTERFACE		
Interfaces	RS232 Serial (up to 57.6k bps), IEEE1284 Parallel (ECP), 10/100BaseT/TX Ethernet (Wired), Wireless (802.11g), USB, RS422/485	
External Connector	Ext. (Applicator I/F): 14-pin Amp	
MEMORY		
Memory	16 MB Standard RAM, 2 MB Standard Flash, Optional 1 MB PCMCIA, Optional 6 MB Flash (Total)	
Processor	32-BIT RISC	
OPERATING CHARACTERISTICS		
Power Requirements	115V/220V (± 10%), 50/60 Hz (± 1%) - Auto-switching	
Environmental Requirements	Operating: 41° to 104°F (5° to 40°C), 15-85% RH, non-condensing Storage: 23° to 140°F (-5° to 60°C), Max. 90% RH, non-condensing	
Dimensions	9.7" (245mm) W x 16.4" (417mm) D x 11.8" (300mm) H	
Weight	25 lbs. (11.34 kg)	
Agency Certifications	CE, UL, CSA, TÜV, FCC Class A	
OTHER FEATURES		
Standard Real Time Clock, Optional Opposite Hand Model		

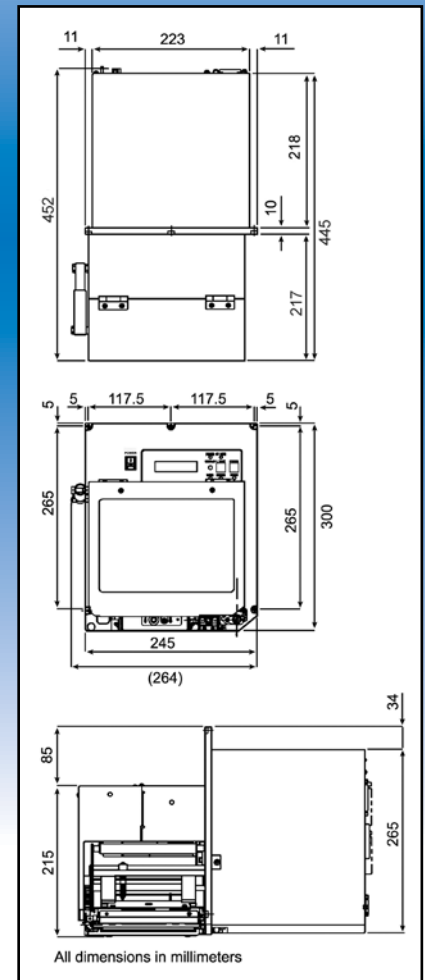

SATO America, Inc.

10350-A Nations Ford Road, Charlotte, NC 28273
Phone: (704) 644-1650 Fax: (704) 644-1662
E-mail: satosales@satoamerica.com

www.satoamerica.com