

# OEM Solutions

The “Standard” for all automatic print & apply Labeling



## M8485Se - High Speed OEM Printer

The M8485Se is the “standard” print engine used in print apply applications around the world. With its 5" print width and maximum print speed of 12 inches per second, the M8485Se is your first choice for high-speed labeling applications.

The industrial OEM high-speed printers are ideal for a range of applications, including:

-  **Compliance Labeling**
-  **Warehouse Logistics**
-  **Pallet Tracking**
-  **Retail Labeling**
-  **Product Authentication**
-  **Cross-Docking**
-  **Shipping Labels**
-  **Weigh-Scale Labeling**
-  **RFID Labeling (optional)**

### Throughput

The M8485Se continues to set the benchmark for OEM printer performance in automatic label applicator systems. Utilizing the latest in 32-bit microprocessor technology, along with 16 MB of standard RAM, the M8485Se provides virtually instantaneous “time to first label out”. When printing at its maximum speed of 12 ips, the M8485Se is capable of handling your most demanding automatic print apply application, especially those where data changes on every label.

### Interchangeable

The height, width and location of mounting holes are identical to earlier SATO OEM print engines, making it easy to upgrade to the M8485Se. Plus, the M8485Se is compatible with the programming commands for the M8400S and the M8485S, making it a simple drop-in replacement.

### Host Interface Flexibility

Designed with a modular interface slot, the M8485Se allows for a wide variety of interface options to be easily installed and field upgraded. These bi-directional interfaces include a high-speed IEEE1284 Parallel (ECP), RS232C Serial, USB, 10BaseT/100BaseTX Ethernet and 802.11g Wireless Ethernet.

### Legendary Reliability

Your labeling application is demanding and uptime is paramount. The M8485Se was designed to provide reliable performance over extended periods of time. It was specifically developed as a high-duty cycle applicator print engine... it is not a repackaged desktop printer. Even the heavy gauge steel enclosure was designed for production environments. Yet, internal access for maintenance is simple.

# SPECIFICATIONS



|  |  |   |
|--|--|---|
| <b>PRINTER MODEL</b>                                   |  | <b>M8485Se</b>  |
| <b>PRINT SPECIFICATIONS</b>                            |  |   |
| Print Method   | Direct Thermal/Thermal Transfer  |   |
| Print Resolution                                       | 203 dpi (8 dpmm)   |   |
| Max. Print Speed                                       | 12"/s (300mm/s)  |   |
| Max. Print Area  | 5" (128mm) W x 49.2" (1249mm) L  |   |
| <b>MEDIA SPECIFICATIONS</b>                            |  |   |
| Sensor Type  | Transmissive sensor for die cut labels & tags.<br>Reflective sensor for use with preprinted sensing marks.<br>Automatic, programmable setting of top form.                                 |   |
| Media Type   | Die cut labels, plain paper facestock and synthetics.<br>Maximum unwind torque: 8 ft./lbs.   |   |
| Back Feed  | Adjustable, $\pm 10"$ (255mm)  |   |
| Media Size   | Width  | Max. 5.27" (134mm)<br>Min. 1" (25mm)  |
|  |  | Min. 4" (102mm) with RFID Tag   |
|  | Length   | Min. 0.24" (6mm)<br>Min. 4" (102mm) with RFID Tag<br><i>Note: Minimum label length at print speeds greater than 6 ips is 1 inch</i>   |
|  | Thickness  | 0.002" – 0.0106" (0.06 mm – 0.268 mm)   |
| Ribbon   | Max. 5.25" (133mm) W x 1968' (600m) L<br>Min. 1.6" (39.5mm) W, Face-In Wind  |   |
| <b>FONT / SYMBOLOGIES</b>                              |  |   |
| Font   | Bitmap - 12 proportional, mono-spaced and outline fonts (Code table 858).<br>Internal CG Triumvirate & CG Times fonts scalable from 2 to 99 points.<br>Optional downloaded TrueType fonts. |   |
| Barcode Symbologies                                    | Linear   | UPC-A/E, EAN-8, EAN-13, Code 39, Code 93, Code 128, Codabar, MSI, Bookland, Industrial 2/5, Interleaved 2/5, Matrix 2/5, Postnet™, GS1-128, GS1-DataBar™, Intelligent Mail® Barcode (IMB) |
|  | 2-D  | PDF417, Micro PDF417, Truncated PDF417, Maxicode™, Data Matrix, QR Code, Composite Symbology  |
| <b>COMMUNICATION INTERFACE</b>                         |  |   |
| Interfaces   | RS232 Serial (up to 57.6k bps), IEEE1284 Parallel (ECP), 10/100BaseT/TX Ethernet (Wired), Wireless (802.11g), USB, RS422/485   |   |
| External Connector                                     | Ext. (Applicator I/F): 14-pin Amp  |   |
| <b>MEMORY</b>  |  |   |
| Memory   | 16 MB Standard RAM, 2 MB Standard Flash,<br>Optional 1 MB PCMCIA, Optional 6 MB Flash (Total)  |   |
| Processor  | 32-BIT RISC  |   |
| <b>OPERATING CHARACTERISTICS</b>                       |  |   |
| Power Requirements                                     | 115V/220V ( $\pm 10\%$ ), 50/60 Hz ( $\pm 1\%$ ) - Auto-switching  |   |
| Environmental Requirements                             | Operating: 41° to 104°F (5° to 40°C), 15-85% RH, non-condensing<br>Storage: 23° to 140°F (-5° to 60°C), Max. 90% RH, non-condensing  |   |
| Dimensions   | 9.7" (245mm) W x 16.4" (417mm) D x 11.8" (300mm) H   |   |
| Weight   | 25 lbs. (11.34 kg)   |   |
| Agency Certifications                                  | CE, UL, CSA, TÜV, FCC Class A  |   |
| <b>OTHER FEATURES</b>                                  |  |   |
| Standard Real Time Clock, Optional Opposite Hand Model |  |   |

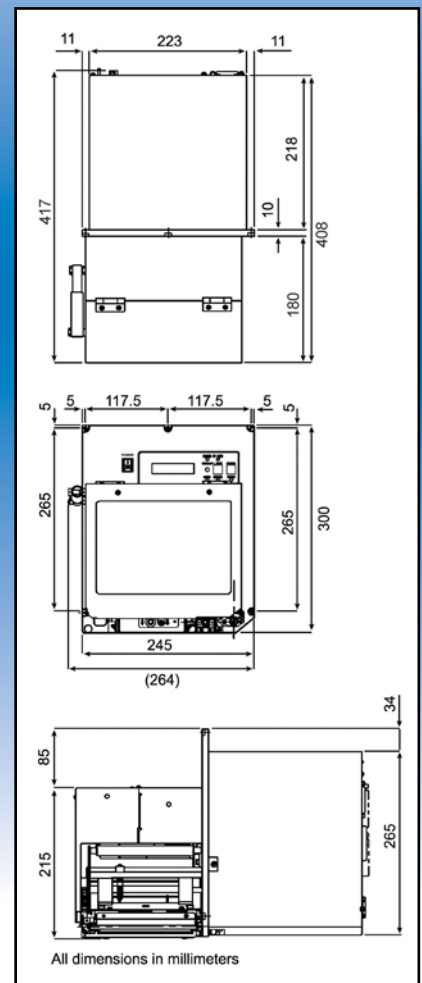

## SATO America, Inc.

10350-A Nations Ford Road, Charlotte, NC 28273  
Phone: (704) 644-1650 Fax: (704) 644-1662  
E-mail: satosales@satoamerica.com

[www.satoamerica.com](http://www.satoamerica.com)