

Model 3139/38-N



Featuring patented vacuumized drum



3139/38-N

Printer Applicator

Have a Label-Aire Authorized Distributor contact you. Visit www.label-aire.com.



3139/38-N Printer Applicator Specifications

The Label-Aire® Model 3139/38-N Printer Applicator makes print and apply labeling even easier.

The Model 3139/38-N Printer Applicator thermal transfer or direct transfer imprints and applies labels around any corner or two labels on adjacent panels utilizing a vacuumized drum.

The Model 3138-N with its built-in label unwind and rewind capabilities is utilized for one-to-one print and apply allowing for the immediate application of each label as it is printed. The 3139/38-N's sturdy swing arm can be configured for cartons or pallets. The heavy duty square-frame mounting stand can be bolted to the floor for added stability. The 3139/38-N is compatible with most O.E.M. printers.

Put this advanced workhorse printer applicator to work for you. The Model 3139/38-N Printer Applicator is designed to run seamlessly in your operation, saving you money in the long run.

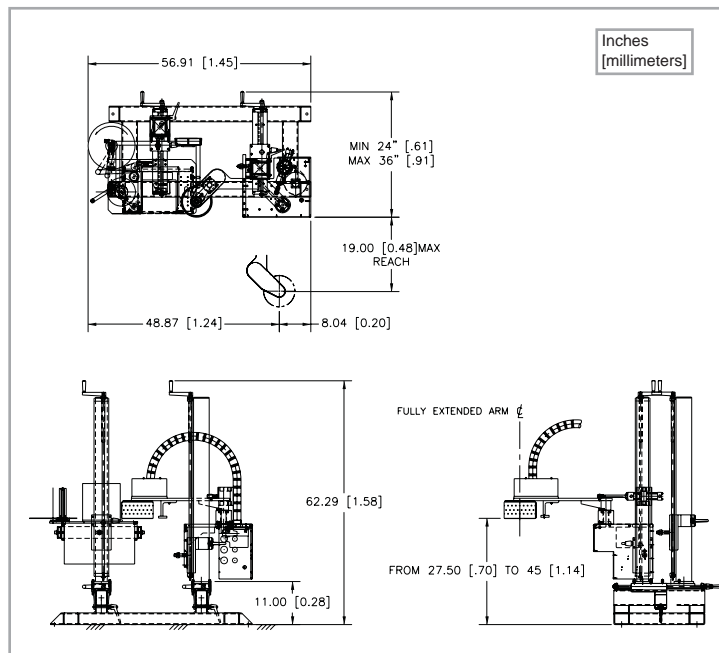

3139/38-N Advanced Features	
Automatic setup	Includes multiple programmable label pages for easy change-overs to different label sizes.
Digital display	Remote operator control capability.
Flash memory	Allows easy download of system software updates.
Advanced I/O	User-configurable for system output.
Heavy duty air cylinder	For heavy duty label application.
Stepper rewind	Comes standard for waste take up.

Dimensions:

Height: 62.29" (1.58 m)
 Length: 56.91" (1.45 m)
 Width: 24" (.61 m) Min. (Max. width dependent upon arm length.)

Weight:

Approx. 500 lbs. (227 kg)

Standard Label Dimensions:

Label Width: Up to 7" (177.8 mm)
 Label Length: Up to 24" (610 mm)
(Printer dependent)

Dispense Speed:

Up to 16" (406 mm) per second depending on printer and label size

Label Placement Accuracy:

Up to +/- 1/8" (.125 mm)

Electrical:

115 Volts AC 60 Hz 5 Amps.
 220 Volts AC 50 Hz

Air (as needed):

4 cfm at 90 psi for most applications

Options:

Most O.E.M. print engines
 Wide range of arm lengths
 RFID configurable
Consult factory for additional options.



Headquarters
 550 Burning Tree Road
 Fullerton, CA 92833 USA

o 714.441.0700
 f 714.526.0300
 e info@label-aire.com
 w www.label-aire.com

Europe
 Sjællandsvej 27A
 DK-9500 Hobro, Denmark

o +45.9657.0063
 f +45.9657.0064
 e info@label-aire.com
 w www.label-aire.com

Asia
 No. 10, Lane 228, Taisi S. Road
 Longjing Township
 Taichung County 434, Taiwan

o +886.4.2395.5684
 f +886.4.2395.8007
 e info@label-aire.com

Distributed by:

MPI Label Systems
 866-364-3585
 www.mpilabels.com
 info@mpilabels.com