

# Applicator Stands

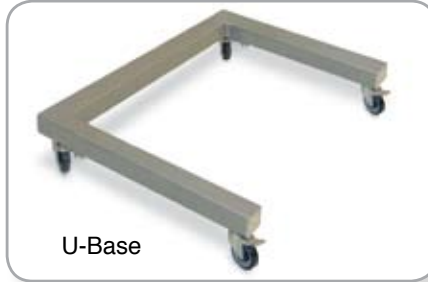

U-Base

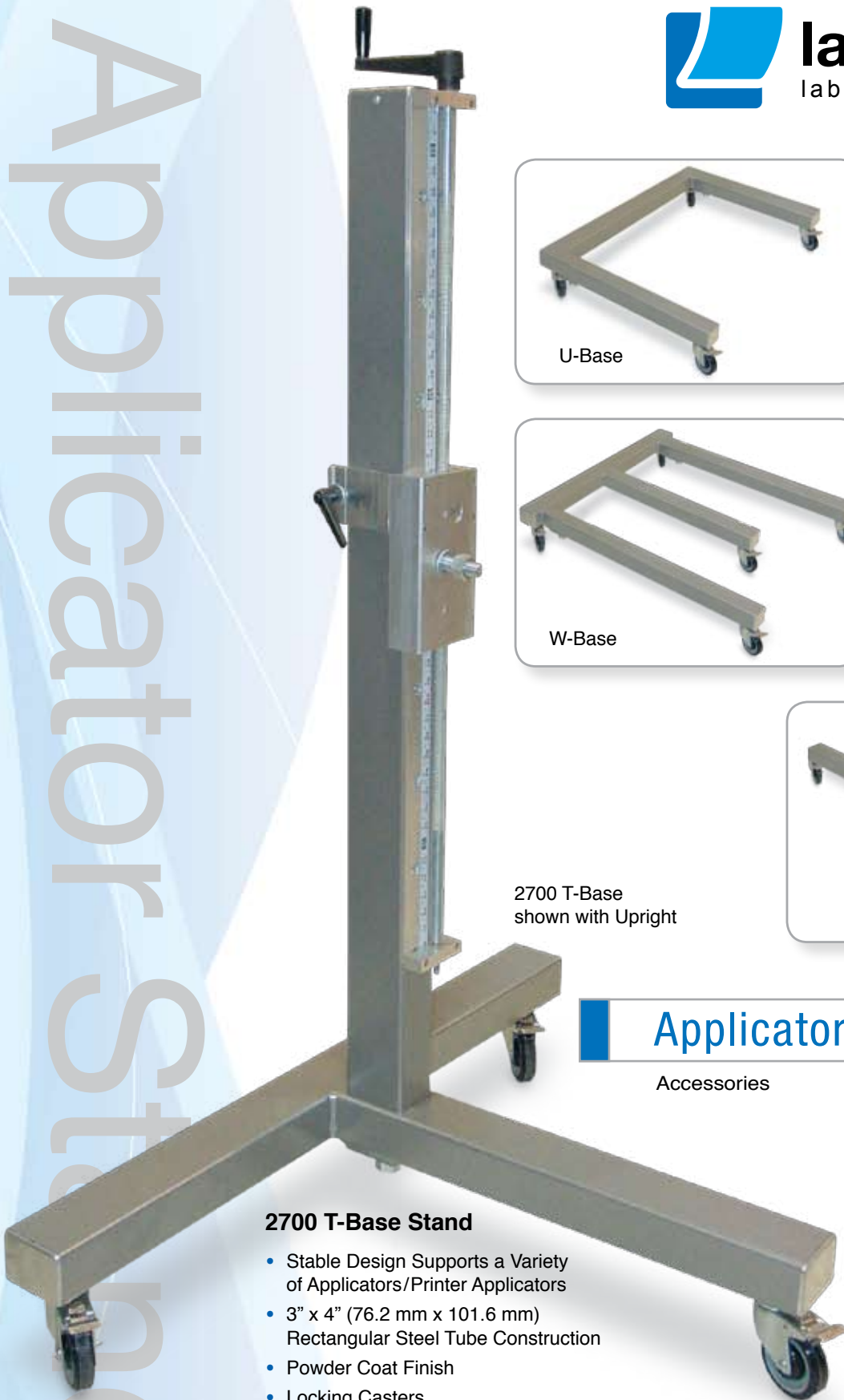
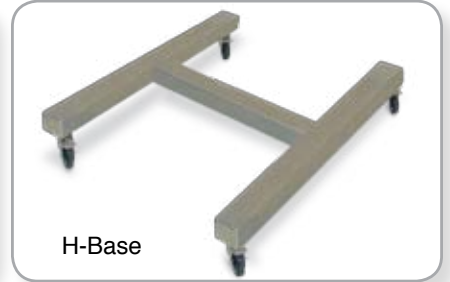

H-Base



W-Base



Low-Boy

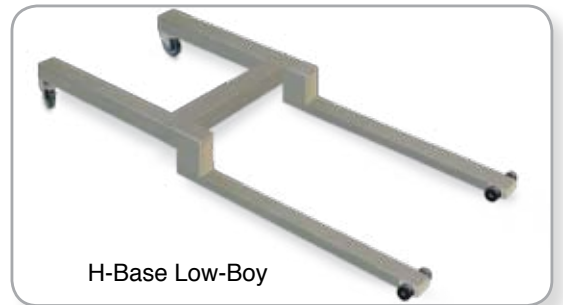

H-Base Low-Boy

2700 T-Base  
shown with Upright

## Applicator Stands

Accessories

### 2700 T-Base Stand

- Stable Design Supports a Variety of Applicators/Printer Applicators
- 3" x 4" (76.2 mm x 101.6 mm) Rectangular Steel Tube Construction
- Powder Coat Finish
- Locking Casters
- Food Grade Casters Available
- Leveling Feet Available
- Stainless Steel Construction Available

*Actual base configuration may vary dependent upon application specifications.*

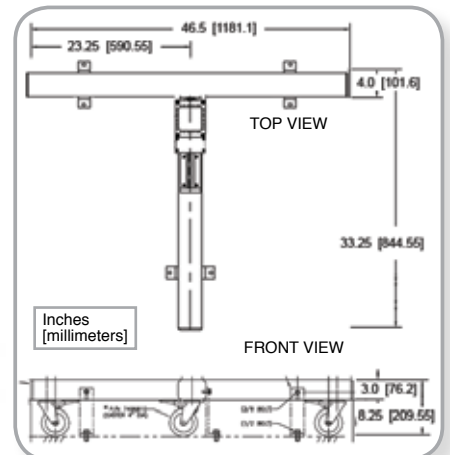

Have a Label-Aire Authorized Distributor contact you. Visit [www.label-aire.com](http://www.label-aire.com).



# Applicator Stands

## Accessories

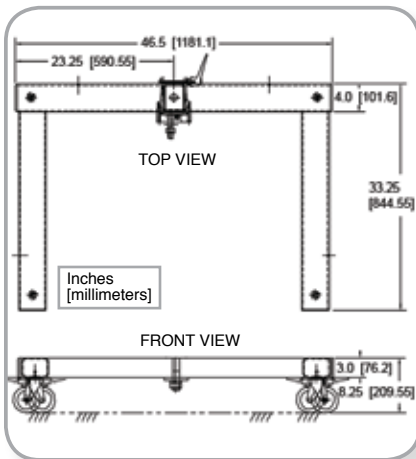

### U-Base Stand

- U-Shape Provides Increased Stability
- For Larger Applicators/ Printer Applicators
- 3" x 4" Rectangular Steel Tube Construction
- Powder Coat Finish
- Locking Casters
- Food Grade Casters Available
- Leveling Feet Available
- Stainless Steel Construction Available

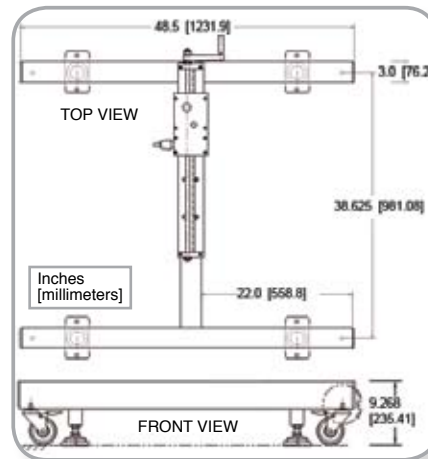

### H-Base Stand

- H-Shape Provides The Most Stability
- For Larger Applicators/ Printer Applicators
- 3" x 4" Rectangular Steel Tube Construction
- Powder Coat Finish
- Locking Casters
- Food Grade Casters Available
- Leveling Feet Available
- Stainless Steel Construction Available

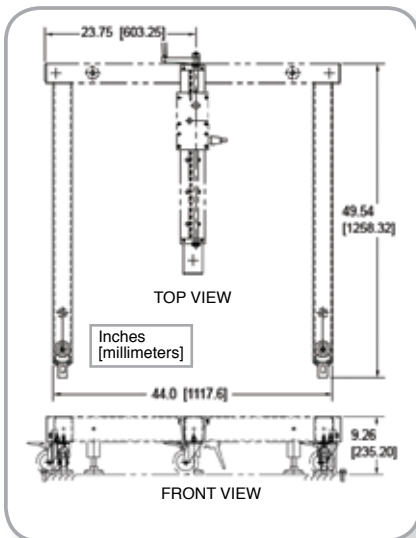

### W-Base Stand

- W-Shape Provides Even Greater Stability
- For Larger Applicators/ Printer Applicators
- 3" x 4" Rectangular Steel Tube Construction
- Powder Coat Finish
- Locking Casters
- Food Grade Casters Available
- Leveling Feet Available
- Stainless Steel Construction Available

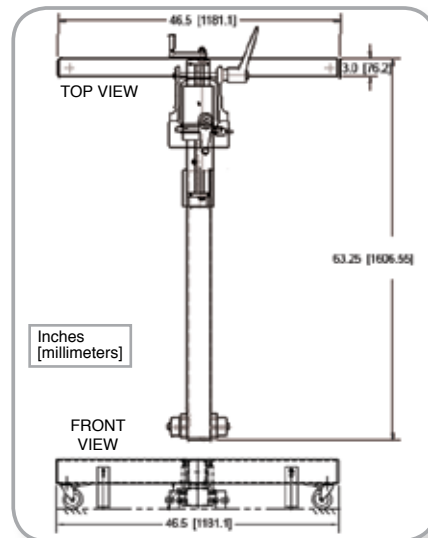

### Low-Boy Stand

- Stable Design Supports A Variety of Applicators/ Printer Applicators
- Low Clearance Design
- 3" x 4" Rectangular Steel Tube Construction
- Powder Coat Finish
- Locking Casters & Low Clearance Casters
- Food Grade Casters Available
- Leveling Feet Available
- Stainless Steel Construction Available

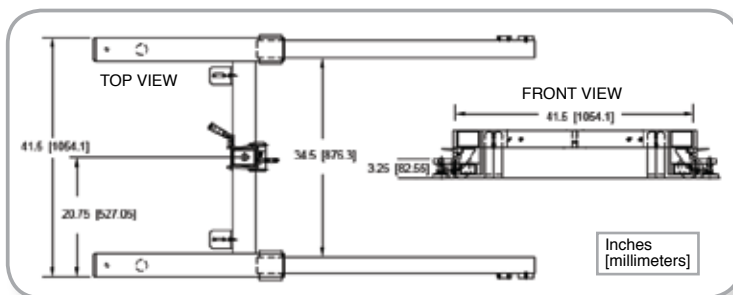

### H-Base Low-Boy Stand

- H-Shape Provides The Most Stability
- Low Clearance Design
- For Larger Applicators/ Printer Applicators
- 3" x 4" Rectangular Steel Tube Construction
- Powder Coat Finish
- Locking Casters & Low Clearance Casters
- Food Grade Casters Available
- Leveling Feet Available
- Stainless Steel Construction Available



#### Headquarters

550 Burning Tree Road  
Fullerton, CA 92833 USA

o 714.449.5105  
f 714.526.0300  
e info@label-aire.com  
w www.label-aire.com

#### Europe

Sjællandsvej 27A  
DK-9500 Hobro, Denmark

o +45.9657.0063  
f +45.9657.0064  
e info@label-aire.com  
w www.label-aire.com

#### Asia

No. 10, Lane 228, Taisi S. Road  
Longjing Township  
Taichung County 434, Taiwan

o +886.4.2395.5684  
f +886.4.2395.8007  
e info@label-aire.com  
w www.label-aire.com

#### Distributed by:

**MPI Label Systems**  
866-364-3585  
www.mpilabels.com  
info@mpilabels.com