

Continuous Feed Dual Unwind Labeler

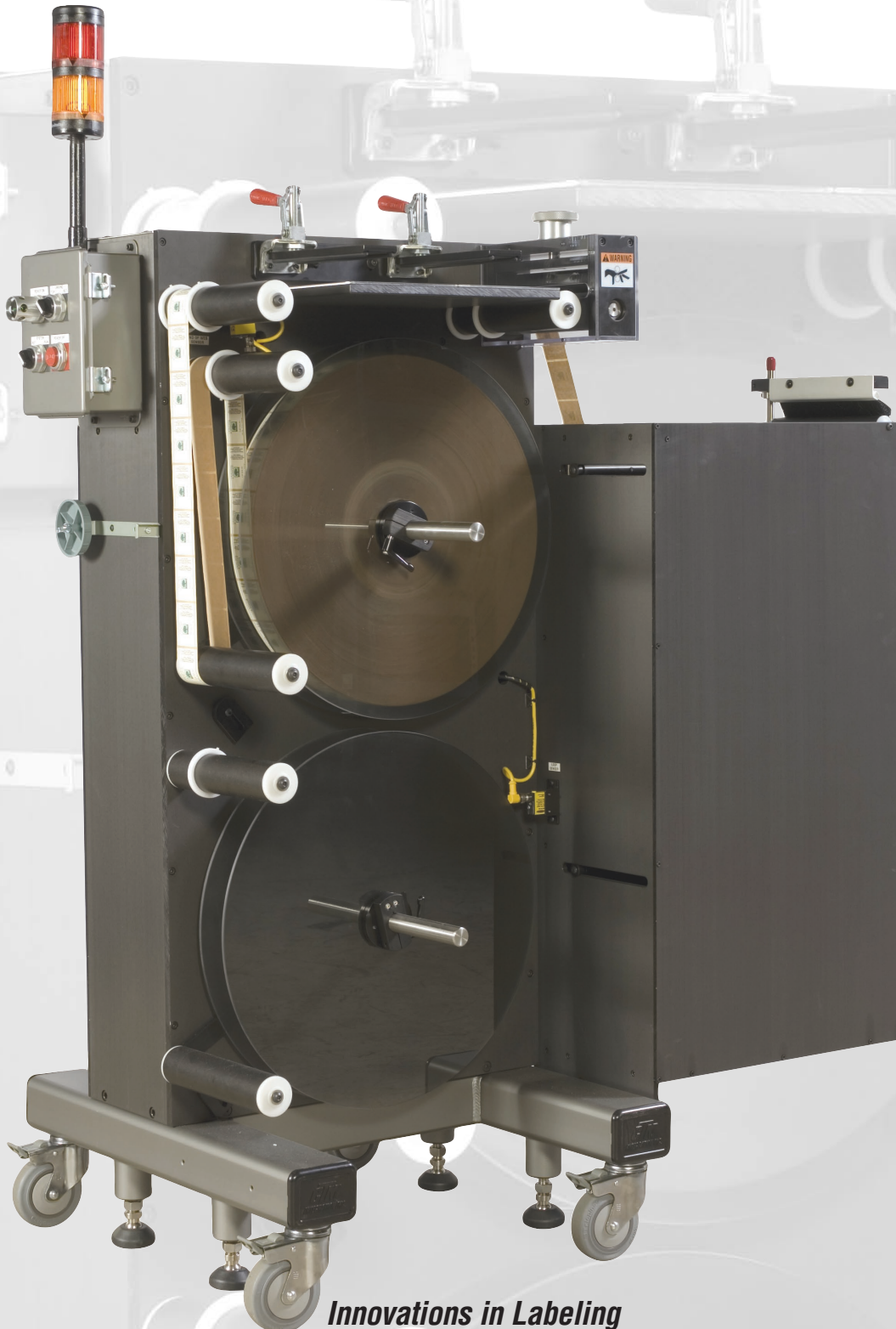
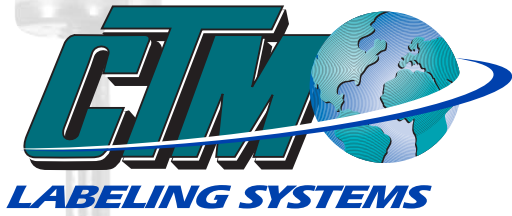

Innovations in Labeling
www.ctmlabelingsystems.com

Continuous Feed Dual Unwind Labeler

Features:

The CTM Continuous Feed Dual Unwind (CFUD) is a stand alone unit designed to eliminate down-time associated with supply roll changeover, therefore increases production speeds.

Continuous feed dual unwinds improve efficiency and lost time of any roll-fed labeler by providing nonstop, uninterrupted label supply at high speeds. The continuous feed dual unwind functions as a standard loose loop controlled powered unit. When the supply roll in use unwinds to a predetermined level, a sensor activates a warning light and signals the drive to feed the remaining labels into a holding bin. The second roll of labels is then spliced to the end of the web as the labels in the bin are consumed. The operator completes the changeover by reloading the empty station and resetting the system for the next changeover.

The CFUD is equipped with low label and end of web alarms with a strobe light indicator as standard features. There is a dual manual clamping system on the splicing table. These features maximize use of label material.

Standard Features:

- PLC Controlled
- Dancer Arm Tension Control
- PLC Enhanced Braking System
- Variable Speed Dispense Rate
- Low Label Alarm
- End of Web Alarm
- Dual Manual Clamping System on Splicing Table

Electrical:

- 120 Volts AC
- 10 Amps
- 50/60 Hertz

Speed:

- Up to 3,000 linear inches per minute (LIPM)

Roll Capacity:

- Dual Supply Rolls
- 20" OD, 3" ID
- (optional core adapters available)

Media Dimensions:

- 7.5" wide, maximum web width

Electronics:

- PLC Controlled

Dimensions:

- 55" h, 47" w, 27" d

Weight:

- 756 lbs.

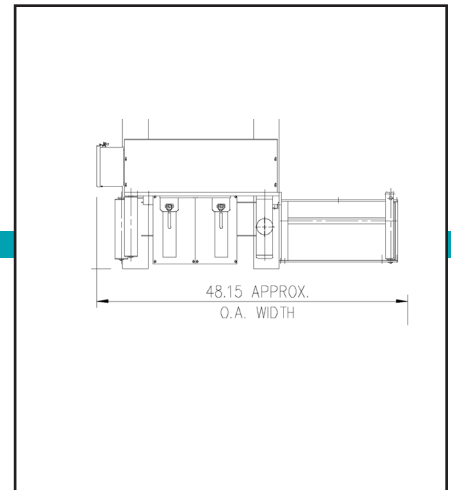
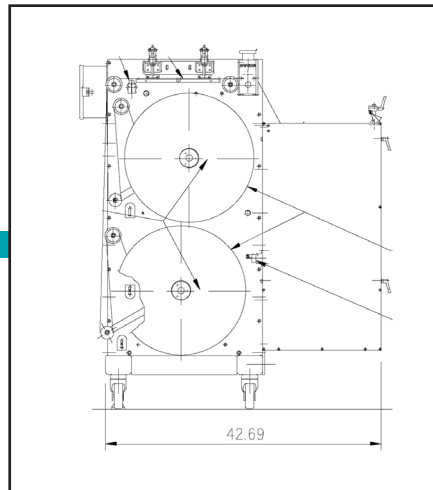
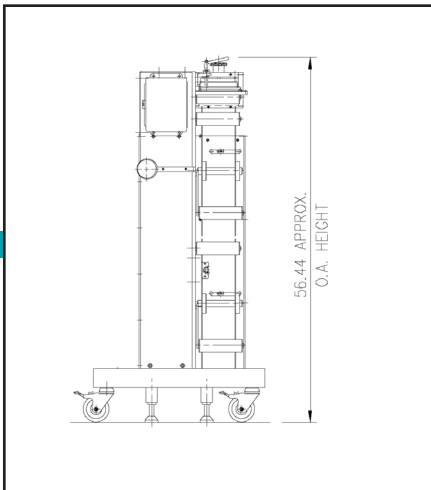

Distributed By:

MPI Label Systems
866-364-3585
www.mpilabels.com
info@mpilabels.com



1318 Quaker Circle
P.O. Box 589
Salem, Ohio 44460
(330) 332-1800

www.ctmlabelingsystems.com

