

The 360FFS Form, Fill and Seal Labeler

CTM **INTEGRATION INC.**
Labeling Systems Built to Last



Innovations in Labeling
www.ctmlabelingsystems.com

The 360FFS Form, Fill and Seal Labeler

Features:

The 360 Series Label Applicator is the most versatile, high performance industrial duty labeler on the market today. The 360 Series Label Applicator has understandably become the benchmark of labelers in its class due to its rugged and versatile design and standard features that are optional on most competitive machines. This labeler is now available in a form fill and seal (FFS) version. The new 360FFS is designed for most form, fill and seal applications along with those applications that allow for a limited amount of space for the labeler. Application needs change? No problem, the 360FFS has an adjustable snorkel that adjusts the applicator's labeling point from 18" to 30". Just one more example of the versatility of the CTM 360 Series workhorse line.

CTM 360FFS Highlights:

- Engineered to minimize the overall applicator size for those "tough to reach" labeling applications.
- Adjustable snorkel length from 18" to 30" to encompass a wide range of labeling applications.
- Stepper drive motor will dispense up to 1500 inches per minute of dispense speed.
- "Auto Teach" label set-up for label length, label stop and label sensor sensitivity.
- Labels per minute rate indicator.
- Totalizing label counter for data management.

Electrical:

108-132 VAC, 50/60 Hertz,
Single Phase, 10 amps.

Air Consumption:

Up to 4 CFM at 60-90 psi.

Labeling Speeds:

Programmable to 1500 inches per minute, in excess of 100 labels per minute depending upon size.

Product Sensing:

Retroreflective scanner provided as standard; plc signal from form, fill and seal unit may be used; custom inputs available.

Label Roll Size:

Maximum 12" OD x 3" ID core

Optional 16" OD or 20" OD x 3" or 6" ID cores

Label Placement:

+/- 1/32"

Dimensions:

22-1/2" Tall x 27-1/2" Deep x 35-1/4" to 47-1/4" Adjustable Length

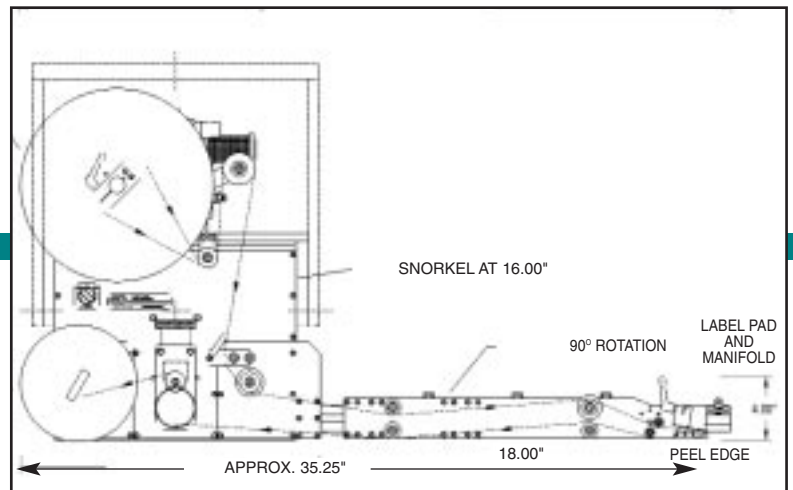
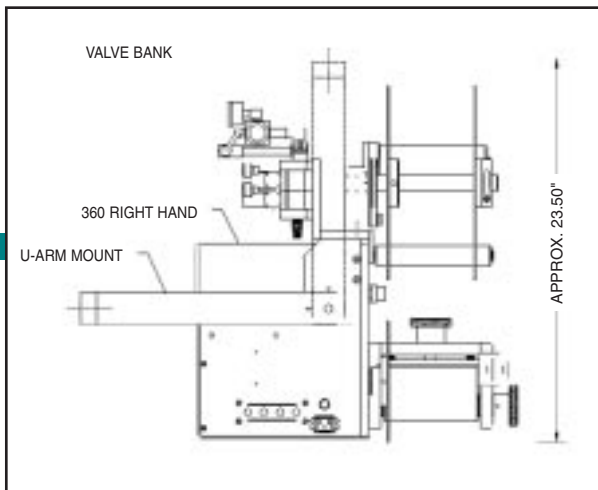

Distributed By:

MPI Label Systems
450 Courtney Rd.
Sebring, OH 44672
Ph: 800.837.2134
www.mpilabels.com
info@mpilabels.com

CTM **INTEGRATION INC.**
Labeling Systems Built to Last

1318 Quaker Circle
P.O. Box 589
Salem, Ohio 44460
(330) 332-1800

www.ctmlabelingsystems.com