



3115 Wipe-On

Primary Applicator

Model 3115

The **Label-Aire® Model 3115** makes labeling easier and faster... making you more profitable.

The Model 3115 Wipe-On labeler delivers on its promise of speed, accuracy, and ease of use. And that translates into lower operating costs and increased productivity for your business.

Advanced features include Automatic Speed Following (ASF) which allows product surface profiling, ensuring wrinkle-free labeling on even the most difficult product shapes and label materials (optional encoder required). Standard speeds of up to 1,500 inches (3,810 cm) of web per minute and Zero Downtime Labeling allow your production to continue without costly interruptions. Product/label queuing and missing label compensation virtually eliminate unlabeled products.

Put this wipe-on pressure-sensitive technology to work for you all day, every day. The Model 3115 Wipe-On labeler is built to meticulous quality standards and designed to withstand the most intense operation.



3115 Wipe-On Advanced Features	
Automatic setup	Includes multiple programmable label pages for easy changeovers to different label sizes.
Stepper motor drive	For precise starting / stopping, increased reliability, wider range speed variability, and lower maintenance.
R3 digital display	Select from five languages (English, French, German, Italian, Spanish), domestic or CE (European) configurations, standard/metric unit display and detailed alarm messages. Can rotate 360°.
Automatic Speed Following (ASF)	Labels are accurately applied even through extreme changes in product line speed.
Quick-action collapsible rewind	Allows easy removal of scrap liner.
Optional smart powered rewind	For improved label accuracy and dynamic web tension control.
Wipe-on applicator	Easily adapts to air-blow or tamp-blow use.

beverage, cd / dvd, coupon / promotional, dairy, direct mail, durable goods, food, health & beauty, nutraceutical, pharmaceutical, tamper-evident labeling

3115

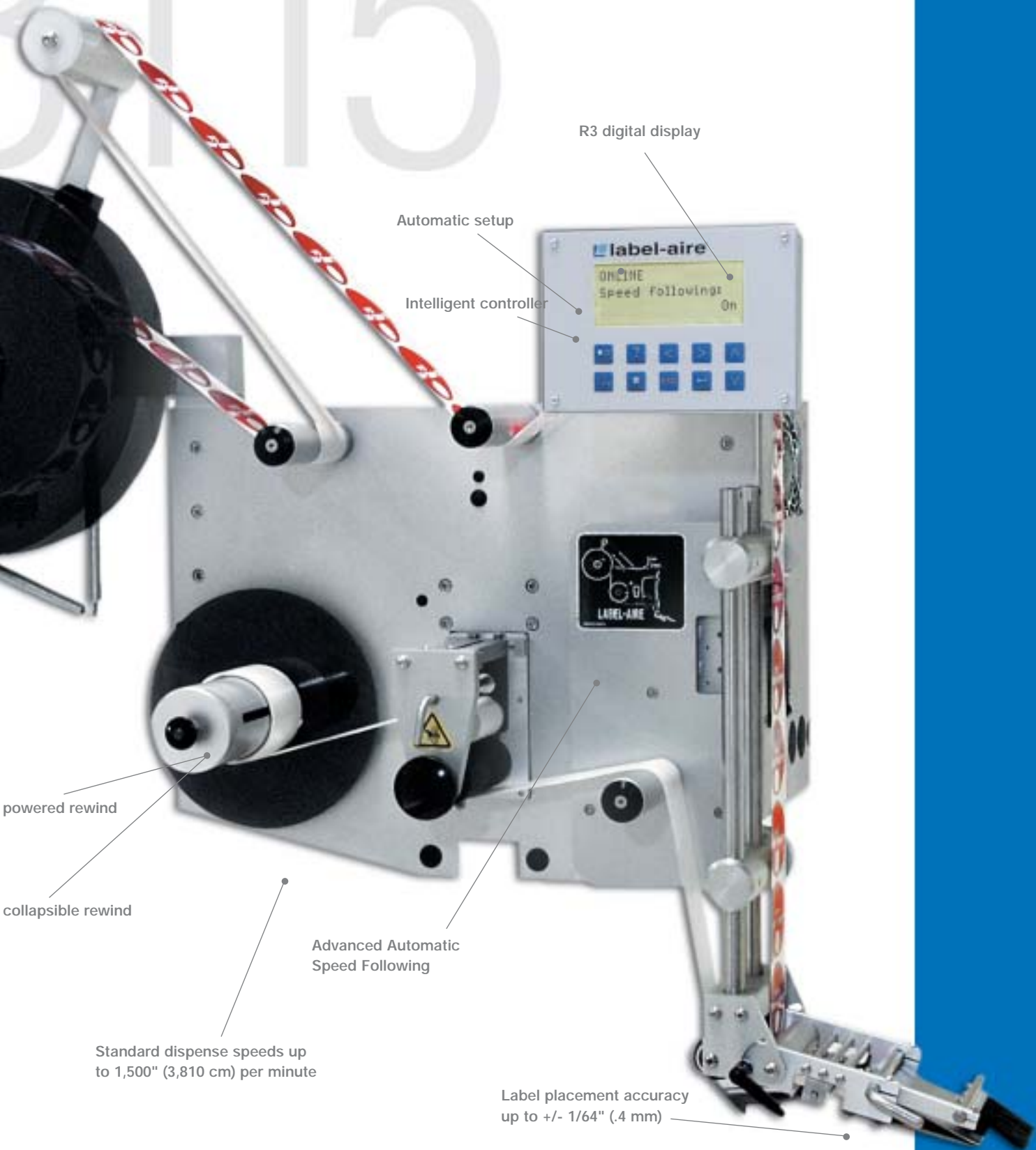

R3 digital display

Automatic setup

Intelligent controller

powered rewind

collapsible rewind

Advanced Automatic
Speed Following

Standard dispense speeds up
to 1,500" (3,810 cm) per minute

Label placement accuracy
up to +/- 1/64" (.4 mm)

3115 Wipe-On Specifications

Dimensions:

Height: 30.41" (772.5 mm)
 Length: 33.44" (849.3 mm)
 Width: 22.84" (580 mm)

Weight:

145 lbs. (65.7 kg)

Standard Label Dimensions:

Max. Web Width: 7.13" (181 mm)
 Min. Web Width: .63" (16 mm)
 Min. Label Length: .5" (13 mm)

Label Packaging:

12" (305 mm) O.D. rolls std. on
 3" (76 mm) I.D. cores
 Up to 16" (406 mm) or 20" (508 mm)
 roll with optional 16" (406 mm)
 non-powered rewind or
 20" (508 mm) powered unwind

Dispense Speed:

Up to 1,500" (3,810 cm) of web per
 minute (standard)
 Up to 2,000" (5,080 cm) of web per
 minute with smart powered rewind

Label Placement Accuracy:

Up to +/- 1/64" (.4 mm)

Electrical:

115 Volts AC 60 Hz 3 Amps.
 220 Volts AC 50 Hz optional

Air (as needed):

2 cfm at 60 psi to 90 psi when
 imprinter is used

Options:

16" (406 mm) non-powered unwind
 Smart 10" (254 mm) powered rewind
 Smart 20" (508 mm) powered unwind
 and powered rewind*
 6" (152 mm) label core adapter
 Encoder kit for Automatic
 Speed Following
 Strobe signals for "low label" and
 "out of labels"
 Clear label sensor upgrade
 Hot stamp imprinter
 Display tilt mounting brackets
 Model 2700 T-Base stand

Consult factory for additional options.

* 4.13" (105 mm) wide applications only

Distributed by:

MPI Label Systems
 450 Courtney Rd.
 Sebring, OH 44672
 Ph: 800.837.2134
 www.mpilabels.com
 info@mpilabels.com

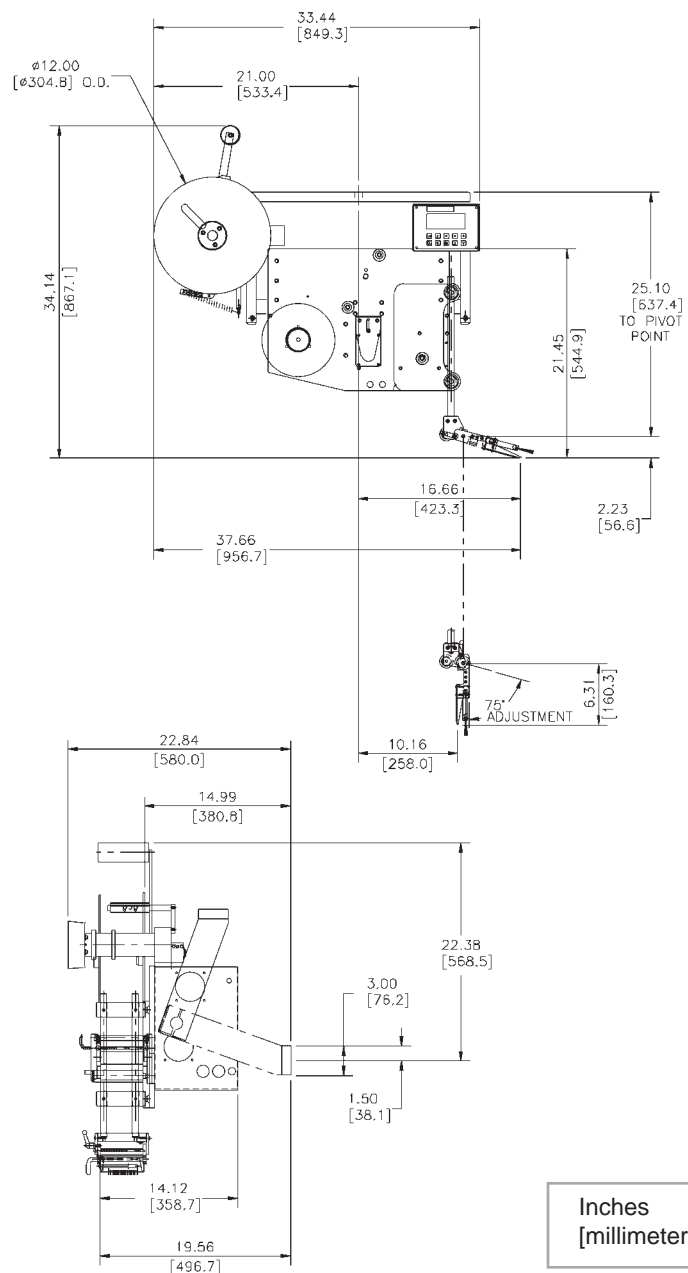

Headquarters

550 Burning Tree Road
 Fullerton, CA 92833 USA

o 714.441.0700
 f 714.526.0300
 e info@label-aire.com
 w www.label-aire.com

Europe

Sjaellandsvej 27A
 DK-9500 Hobro, Denmark

o +45 9657 0063
 f +45 9657 0064
 e info@label-aire.com
 w www.label-aire.com