

2111/14

Model 2111/14 EAS Labeler

 LABEL-AIRE®

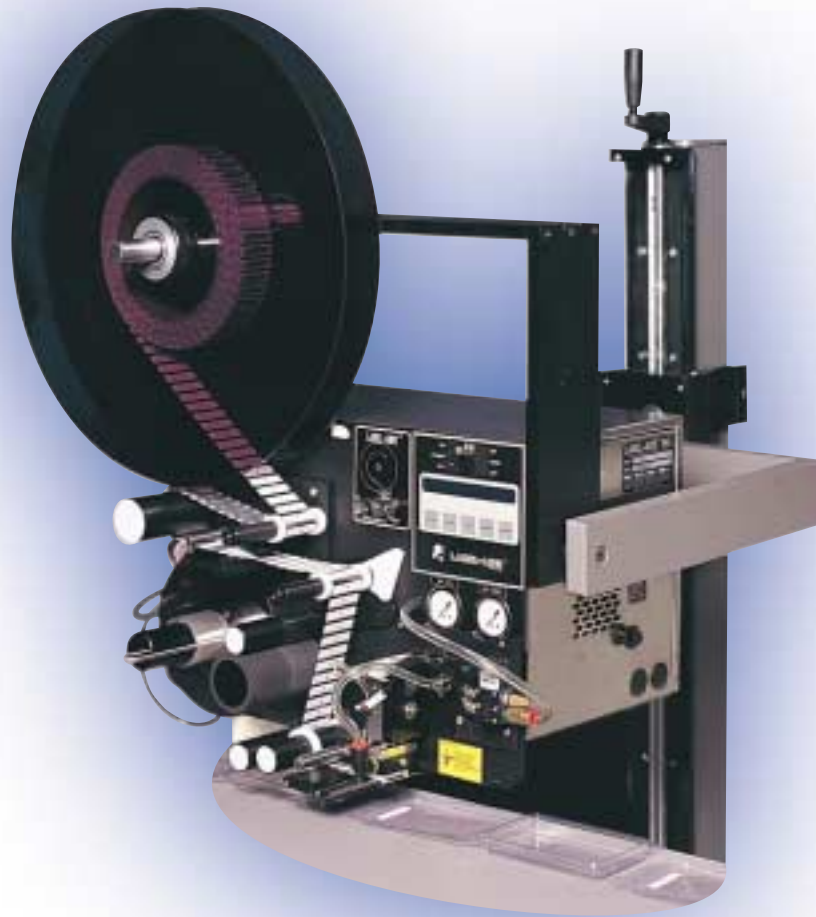

precision

LABEL-AIRE®... LABELING SOLUTIONS THAT APPLY™

2111/14

! LABEL-AIRE®

Model 2111/14 EAS Labeler

Are you looking for a way to apply Sensormatic or Checkpoint security tags more affordably and efficiently? The Label-Aire® Model 2111/14 Electronic Article Surveillance labeler uses advanced technology that gives you enhanced performance.

The Model 2111/14 Electronic Article Surveillance labeler applies Checkpoint or Sensormatic security tags to virtually any product resulting in controlled losses and reduced costs for retailers. This microprocessor-controlled labeler is equipped with an advanced stepper drive for increased versatility and durability. Standard options include a variety of drop down and extended snorkels to reach into tight spaces, a 14" (356 mm) or 20" (508 mm) non-powered unwind, Checkpoint or Sensormatic EAS changeover kit for added versatility, velocity compensation – to ensure accurate placement though product speed changes and application speeds up to 300 labels per minute. The 2111/14's rugged corrosion resistant, stainless steel and anodized aluminum housing provides durability and maintenance-free operation even in hostile environments.

- Uses Checkpoint or Sensormatic security tags for theft prevention of goods.
- High speed of 300 labels per minute ensure efficient operation and cost savings.
- Microprocessor controlled with repeatable settings and constant monitoring ensures reliable operation.
- Stepper-driven means "no wear parts" making it easier on your bottom line.
- Available drop down and extended snorkels for labeling in tight spaces.

! LABEL-AIRE®

550 Burning Tree Road
Fullerton, CA 92833 USA
v: 714-441-0700 f: 714-526-0300

Sjaellandsvej 27 A
Hobro, DK-9500 Denmark
v: 45 96 57 00 63 f: 45 96 57 00 64

e: info@label-aire.com
i: www.label-aire.com

Distributed by:

MPI Label Systems
450 Courtney Rd.
Sebring, OH 44672
Ph: 800.837.2134
www.mpilabels.com
info@mpilabels.com

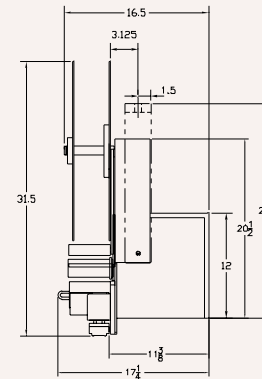
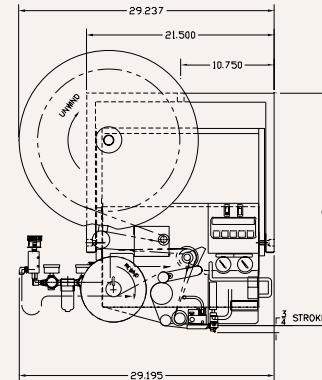

S P E C S

Dimensions:

Height: 33" (838 mm)
Width: 17" (432 mm)
Length: 29" (737 mm)

Weight:

150 lbs. (71 kg)

Label Dimensions:

Most sizes available

Label Packaging:

20" (508 mm) O.D. rolls maximum (Sensormatic)
14" (356 mm) O.D. maximum (Checkpoint)
Fanfold available with Sensormatic tags

Dispense Speed:

Up to 300 labels per minute

Label Placement Accuracy:

Up to +/- 1/16" (1.6 mm) Checkpoint tags
Up to +/- 1/32" (0.8 mm) Sensormatic tags

Electrical:

115 Volts AC 60 Hz 5 Amps.
220 Volts AC 50 Hz optional

Air:

4 cfm at 90 psi for most applications

Options:

14" (356 mm) or 20" (508 mm) non-powered unwind
10" (254 mm) drop down snorkel
Velocity compensation
Strobe signal for "low label" or "out of labels"

Label-Aire also provides a full range of rotary & inline systems, label applicators, printer applicators, and custom systems to meet your toughest labeling requirements.

IMPAXX
THE COMPLETE PACKAGE
MACHINE SYSTEMS