

2111

 LABEL-AIRE®

Model 2111 HS



precision

LABEL-AIRE®... LABELING SOLUTIONS THAT APPLY™

# Model 2111 HS

**The Label-Aire® Model 2111 HS is a high speed label applicator you can depend on for those critical applications.**

The Label-Aire 2111 HS “high speed” label applicator can apply labels accurately at a blistering 1000 labels/minute. The 2111 HS utilizes Label-Aire’s innovative Air Blow technology which retains the label by vacuum on a honeycomb applicator grid. At the precise moment the product passes under the grid, the label is blown onto the product. Double labeling or missed product are eliminated with peel tip sensing which permits repeatable settings and constant monitoring. The 2111 HS also features a DC Servo which allows the unit to handle up to 5000 inches/minute at peak velocity.

Label-Aire’s 2111 HS offers added versatility in that it can be mounted in almost any position adjacent to the production line to apply labels to the tops, sides, or bottoms of products.

- Servo-driven means unmatched speeds and increased label placement accuracy.
- Microprocessor controlled with repeatable settings ensure reliable operation
- Dual 20” (508 mm) diameter Non-Stop Dual Unwinder decreases down-time associated with roll changes.
- Can be converted to left- or right-hand use.
- Available in either CD (domestic) or CE (European) configurations.
- Can be mounted in almost any position adjacent to the production line.
- Applies labels to the tops sides, or bottoms of products for added versatility.



550 Burning Tree Road  
Fullerton, CA 92833 USA  
v: 714-441-0700 f: 714-526-0300

Sjaellandsvej 27 A  
Hobro, DK-9500 Denmark  
v: 45 96 57 00 63 f: 45 96 57 00 64

e: info@label-aire.com  
i: www.label-aire.com

Distributed by:

MPI Label Systems  
450 Courtney Rd.  
Sebring, OH 44672  
Ph: 800.837.2134  
www.mpilabels.com  
info@mpilabels.com

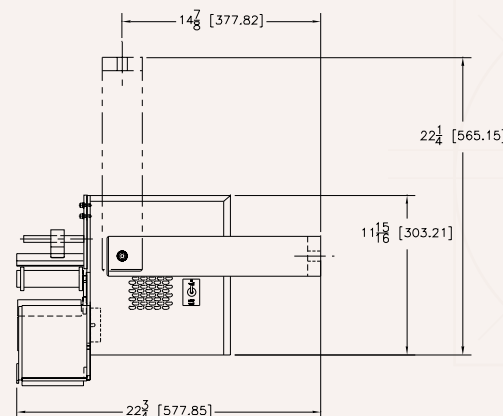
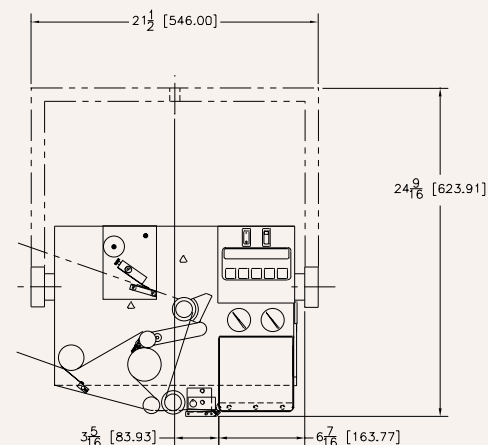

## S P E C S

### Dimensions:

Height: 24.6" (625 mm)  
Length: 21.5" (546 mm)  
Width: 11.9" (302 mm)

**Weight:** 130 lbs. (59 kg.)

### Standard Label Dimensions:

Min.: .75" x .75" (19 mm x 19 mm)  
Max.: 3" x 3" (76 mm x 76 mm)

**Label Packaging:** Refer to Auto-Splicer or Non-Stop Dual Unwind product info

**Dispense Speed:** Up to 1000 labels per minute depending on label size

### Static Stack Accuracy:

+/- 1/32" (.8 mm)

### Electrical:

120 Volts, 60 Hz, 5 Amps.  
220 Volts, 50 Hz, 5 Amps.

### Air:

3 cfm at 90 psi for most applications

### Options:

Label-Aire Non-Stop Dual Unwinder  
Label-Aire Autosplicer  
Velocity compensation  
Strobe signal for “low label” or “out of labels”

Label-Aire also provides a full range of rotary & inline systems, label applicators, printer applicators, and custom systems to meet your toughest labeling requirements.